

GRAY OWL

— FARMHOUSE —



M A N U A L





Welcome Page

Welcome to our cozy retreat at 2118 Madron Lake Rd., Buchanan, Michigan! We're thrilled to have you and hope you find your stay both relaxing and enjoyable. This guide is designed to help you get acquainted with the property and its amenities.

Table of Contents

- Welcome Page (P.2)
- Table of Contents (P.3)
- Arrival and Departure Details (P.4)
 - Check-In Instructions with Yale Smart Lock (P.4)
 - Check-Out Instructions with Yale Smart Lock (P.6)
- Rental House Rules (P.7)
- Amenities and Property Features (P.8)
- Directions for Appliances and Electronics (P.9)
 - TV (P.9)
 - Thermostat (P.14)
 - Coffee Maker (P.15)
 - Washer and Dryer (P.20)
 - Grill (P.28)
 - Shower (P.29)
 - Fireplace (P.30)
 - Stove (P.32)
 - Refrigerator (P.36)
 - Dishwasher (P.41)
 - Fire Pit (P.46)
 - Safety and Usage (P.47)
- Outside Patio Furniture (P.48)
- Garbage Information (P.49)
- Guest Wi-Fi and Technology Use (P.50)
- Property Layout and Access (P.51)
- Emergency Contacts and Safety Information (P.52)
- Security Measures (P.53)
- Social Media Participation (P.54)
- Final Note (P.55)

Arrival and Departure Details

Rental Address: 2118 Madron Lake Rd., Buchanan, Michigan

Check-In Instructions with Yale Smart Lock 4:00 pm EST

1. **Before Arrival:** A few days before your scheduled arrival, we will send you a unique PIN code for the Yale smart lock via Airbnb messaging. This code is exclusively yours for the duration of your stay and ensures your security and convenience.
2. **Arrival at the Property:** Upon arriving at the property located at 2118 Madron Lake Rd., Buchanan, Michigan, approach the front door where you will find the Yale smart lock.
3. **Entering Your PIN:** On the smart lock keypad, press the "Yale" button (example below circled in red), enter the unique PIN code provided to you. After entering the code, press the "✓" button (example below pointed to with a green arrow) to unlock the door. If the correct code is entered, the lock will disengage, allowing you to turn the handle and open the door.
4. **Inside the House:** Once inside, you will find a welcome guide on the entryway table. This guide includes all the information you need about the house amenities, Wi-Fi details, and how to use the appliances. Please take a moment to familiarize yourself with the house rules and safety information.
5. **If You Have Any Issues:** If you face any difficulty entering the code or if the lock does not seem to work, please contact us immediately through Airbnb messaging or at the emergency contact number provided in your welcome message. We are here to ensure your check-in process is as smooth as possible.



Check-Out Instructions with Yale Smart Lock 11:00 am EST

1. **Before Departure:** Ensure all windows are closed, and the lights, appliances, and electronics are turned off. Please follow any specific check-out procedures listed in the welcome guide, such as taking out the trash, running the dishwasher, used towels in laundry baskets.
2. **Leaving the House:** After you have packed up and are ready to leave, make sure the door to the property is firmly closed behind you.
3. **Locking the Door:** To lock the door, simply press the "yale" button on the Yale smart lock keypad and the door will automatically lock. Ensure the door has locked properly by turning the handle to test.



4. **Final Steps:** Once the door is securely locked, please send us a quick message through Airbnb to let us know you have departed. This allows us to prepare the house for our next guests and ensure everything is in order.

Rental House Rules

Please respect our home and the quiet nature of the neighborhood. Detailed rules include:

- Maximum number of people staying (unless prior approval) is 6.
- No parties or events without prior approval.
- Respect check-in and check-out times to ensure proper cleaning and maintenance.
- Participate responsibly if visiting with pets (if pre-approved).
 - If approved, please clean up after your pet.
- No smoking or recreational drug use on the property (you may smoke outside the home).
- Please respect the property and leave it in the condition you found it.
- Garbage is collected on Fridays; please ensure all trash is placed in the bins provided and brought to the edge of the driveway Thursday night for 5am pickup Friday.
- Follow specific instructions for appliance use and property amenities.
- Respect the noise level and neighborhood peace and quiet hours after 10 pm.

Amenities and Property Features

- **Wi-Fi:** Network: Farmhouse2118, Password: OldMacDonaldFarm1998
- **Amenities:** Electric Fireplace, Washer, Dryer, Grill, Coffee Maker, TV with Netflix, Prime, and Hulu access (streaming services require your own account).
- **Extras:** Games (upstairs closet by bathroom), extra towels (upstairs closet by bathroom), toilet paper (main entryway bathroom closet).

Directions for Appliances and Electronics

TV (Hisense 65R6E4)

- **Turning On/Off:** Use the remote control power button to turn the TV on or off.
- **Basic Operation:** Use the remote to navigate free channels, adjust volume, and access the menu for settings.
- **Accessing Streaming Services (Netflix, Hulu, Etc.):**
 1. Press the "Home" button on the remote.
 2. Navigate to the "Apps" section using the arrow keys.
 3. Select Netflix or Hulu from the apps available. You might need to log in with your account details.

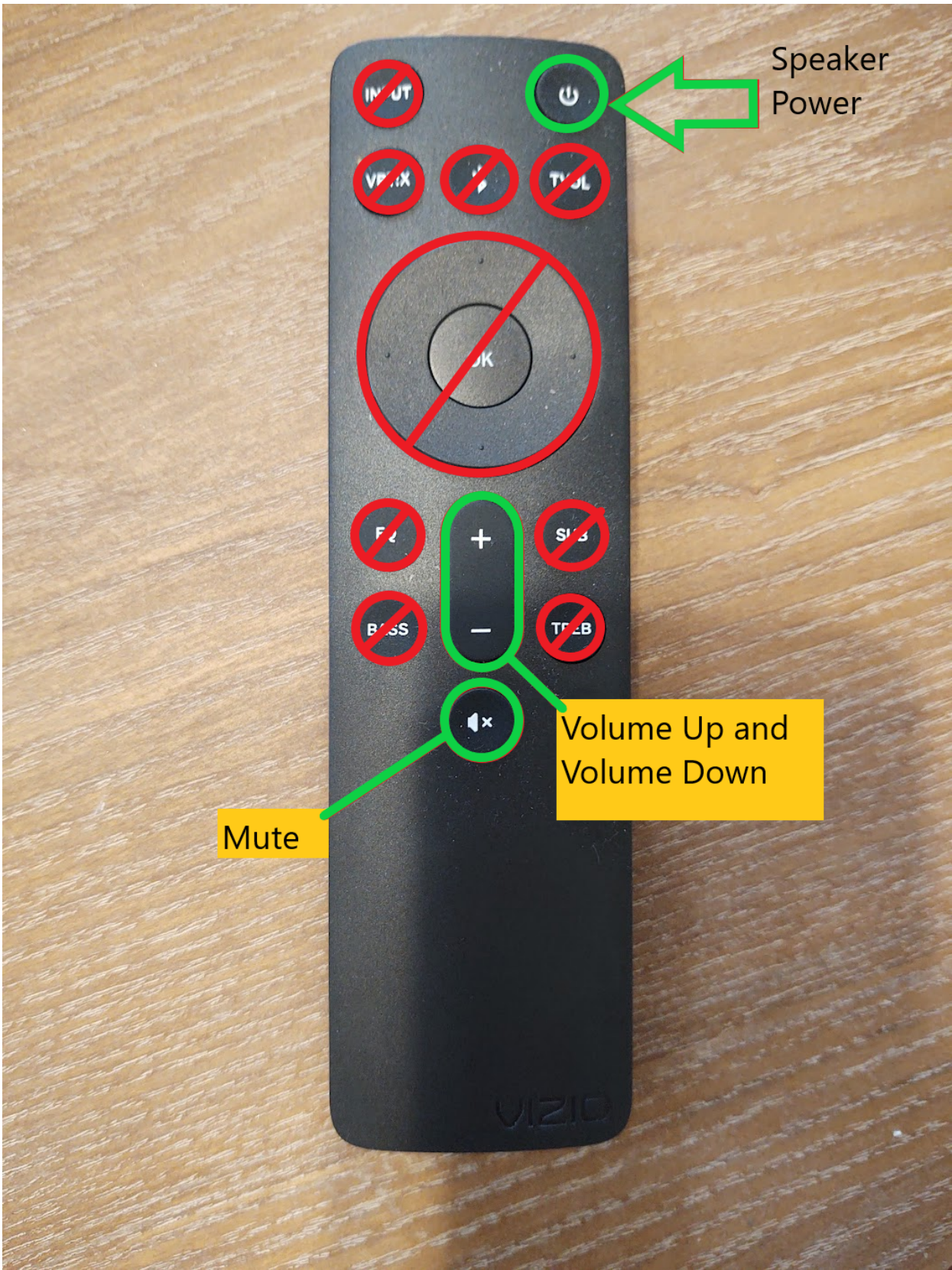











TV Power

Home Button for All Apps

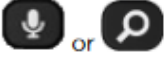
Navigational Buttons for Selecting and Confirming

BUTTON	FUNCTION	DESCRIPTION
	POWER	Turns TV on and off.
	BACK	<ul style="list-style-type: none"> • Menu: Goes back to previous menu/screen. • Home screen tile: Moves highlight back to the Home screen option. • Watching live TV or a TV input: Returns to Home screen. • Playing streaming content: Stops playing stream and returns to the previous menu or screen. • Browsing streaming content: Goes to the previous level in the content tree.
	HOME	Immediately returns to the Home screen.
	DIRECTIONAL PAD	<ul style="list-style-type: none"> • Moves the highlight in the corresponding direction. • OK chooses the highlighted option. <p>While watching TV:</p> <ul style="list-style-type: none"> • UP/DOWN changes channel. • LEFT displays the Live TV Channel Guide (connected mode) or channel list (non-connected mode). • LEFT/RIGHT TVs operating in non-connected mode: while in the channel list switches between ALL CHANNELS and FAVORITE CHANNELS. <i>TVs with Live TV Pause enabled:</i> when the program is paused, moves backward/forward approximately 10 seconds in the program buffer. • While in the channel list, OK selects the highlighted channel. While watching live TV: displays the program information banner.

BUTTON	FUNCTION	DESCRIPTION
	VOICE or SEARCH	<p><i>Only on select models with Roku Voice remotes, hold and say the name of a movie, TV program, actor, director, or genre, including the special genres "free" and "4K." Or, say a command to start streaming, change a channel, and more¹.</i></p> <p>For more information, go to: go.roku.com/voicesearch</p>
	REPLAY	<p><i>Select models.</i> Streaming programs that support this feature and TVs with Live TV Pause enabled, jumps back a few seconds with each press and resumes playing.</p> <p>If Live TV Pause is disabled, jumps to previous channel.</p> <p>When using an on-screen keyboard: Backspaces in the text you are entering.</p> <p>In the Live TV Channel Guide²: Returns to the current day and time.</p>
	◀◀ REWIND ▶▶ PLAY/PAUSE ▶▶▶ FAST FWD	<p>Scan backward, pause, play, and scan forward in streaming content and live TV channels (if Live TV Pause is enabled).</p> <p>Press REWIND ◀◀ or FAST FWD ▶▶▶ one, two, or three times to control the speed of the operation.</p> <p>REWIND ◀◀ and FAST FWD ▶▶▶ also jump backward and forward one screen at a time when viewing long lists, such as when you are browsing programs in the channel list or Live TV Channel Guide¹.</p>
	STAR	<p>Displays additional options when available. On-screen hints let you know when this button is active.</p>

Thermostat

For a visual and auditory guide, please scan the QR code below



or type in <https://youtu.be/cD4ZVG3C7As?si=z9vPp8PwJlawXGAL> in your internet browser.

- **Adjusting Temperature (Located in Living Room near the stairs):**
 1. Approach the thermostat and the display should light up.
 2. Slide your finger up or down the right side of the thermostat and tap the right side again to select the value to adjust (the temperature of the home will remain between the two values)
 3. After tapping to select the boundary you want to update, slide your finger up or down the right side to increase or decrease the value.

Coffee Maker (Hamilton Beach)

- **Brewing Drip Coffee:**

1. Open the lid and add water to the reservoir (follow markings for desired cups).
2. Place a coffee filter in the basket and add ground coffee (about 1 tablespoon or 15g per cup).
3. Close the lid and press the "brew now" button to start. The coffee will begin to drip into the carafe below.

- **Brewing K-Cup Coffee:**

1. Open the lid and add water to the reservoir (follow markings for desired cups).
2. Place a single K-Cup in the slot.
4. Close the lid and press the desired cup size to start. The coffee will begin to drip into the cup below.

Parts and Features

1	Carafe Side Lid
2	Carafe Water Reservoir (with markings for measuring)
3	Brew Basket
4	Swivel Shower Head
5	Control Panel
6	Carafe
7	Warming Plate
8	Removable Cup Rest/Storage Container
9	Cord Stuff Storage
10	Funnel
11	Single-Serve Lid Latch
12	Removable Single-Serve 40 oz. Water Reservoir with Removable Lid
13	Removable Single-Serve Brew Basket for Ground Coffee with Hinged Lid and Handle
14	Gray Removable Single-Serve Pod Holder with Handle
15	Gray Removable Needle Holder with Black Seal
16	Piercing Needle
17	Black Seal
18	Single-Serve Side Lid

Before first use: Wash all removable parts in hot, soapy water. Rinse and dry. Brew one cycle with water on each side and discard water.

To order parts, visit hamiltonbeach.com/parts

(on back)

How to Brew a Single-Serve Pod

⚠ WARNING Burn Hazard.

If overflow occurs, unplug and allow coffee maker to cool.

To avoid hot coffee overflowing:

- Fully insert cup or travel mug on drip tray.
- Do not lift lid during the brewing process.

⚠ CAUTION Cut Hazard.

Removable single-serve pod holder has a sharp needle. Piercing needle on underside of lid is also sharp. Use caution when handling.

NOTES:

- If Lid is opened after, BREW NOW I/O or CARAFE (☐) button was pressed, discard contents of cup or travel mug. Discard used Pod. Add new Pod and press BREW NOW I/O button to restart brewing cycle.
- Use only cold water in Reservoir. Do not use hot water.
- Do not reheat coffee in machine.
- Do not use creamer or nondairy creamer in Reservoir.
- After brewing hot cocoa single-serve pods, brew a water-only cycle without a single-serve pod to avoid possibility of clogging Piercing Needle.
- Press BREW NOW I/O button again to stop brewing midcycle.
- If brew indicator light flashes three times, Lid is not closed. Lower Lid until it clicks to lock. Press BREW NOW I/O button.
- Do not brew coffee without Removable Needle Holder locked into place.

1. Lift up Single-Serve Water Reservoir and remove Lid. Add water to at least MIN fill line (15 oz. [444 ml]) or MAX fill line (40 oz. [1.2 L]).
2. Plug into outlet.
3. Press CUP SIZE (☒) button and select 8, 10, or 14 oz.
4. Lift Lid Latch until Lid clicks into place.
5. Place Gray Removable Single-Serve Pod Holder in Funnel.
6. Place a pod into Single-Serve Pod Holder. Do not remove foil.
7. Close Lid and snap in place to pierce single-serve pod.
8. Press BREW STRENGTH (☑) button to select regular or bold.
9. Use Cup Rest for a cup or mug and remove Cup Rest for a travel mug.
10. Press BREW NOW I/O button to start brewing. Brew indicator light will light up to show that Coffee Maker is brewing. Coffee Maker will shut off automatically when brewing is complete.
11. Unplug.
12. Single-Serve Pod Holder should be rinsed after every use.

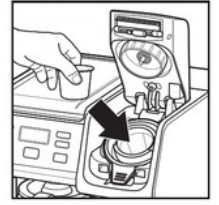
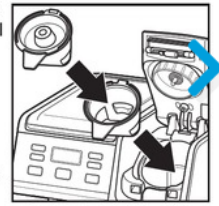

5

How to Brew Single-Serve Ground Coffee

⚠ WARNING Burn Hazard.

If overflow occurs, unplug and allow coffee maker to cool.

To avoid hot coffee overflowing:

- Fully insert cup or travel mug on drip tray.
- Remove single-serve pod holder before adding coffee grounds to brew basket.
- To avoid overflow, keep ground coffee below MAX fill line.
- Do not lift lid during the brewing process.
- If brew cycle is stopped early, the coffee must be drained. Return cup or travel mug to drip tray/cup rest. Place a mug on drip tray/cup rest. Press the BREW NOW I/O button. Failure to drain the cup or travel mug can cause the next cup brewed to overflow.

⚠ CAUTION Cut Hazard.

Piercing needle on underside of lid is sharp. Use caution when handling.

NOTES:

- Use only cold water in Reservoir. Do not use hot water.
- Do not reheat coffee in machine.
- Do not use creamer or nondairy creamer in Reservoir.
- Do not use hot cocoa powder or mix in Brew Basket.
- If finer ground coffee is used, coffee will continue to drip after light has gone off.
- Press BREW NOW I/O button again to stop brewing midcycle.
- If brew indicator light flashes three times, Lid is not closed. Lower Lid until it clicks to lock. Press BREW NOW I/O button.
- Do not brew coffee without Brown Removable Brew Basket in place.
- If you have sediment from coffee, add a #1 paper cone coffee filter to Brown Removable Brew Basket.
- Do not brew coffee without Removable Needle Holder locked into place.

1. Lift up Single-Serve Water Reservoir and remove Lid. Add water to at least MIN fill line (15 oz. [444 ml]) or MAX fill line (40 oz. [1.2 L]).
2. Plug into outlet.
3. Press CUP SIZE (☒) button and select 8, 10, or 14 oz.
4. Lift Lid Latch until Lid clicks into place.
5. Open Brew Basket Lid; then place Brown Removable Brew Basket on counter top.
6. Add ground coffee to Brown Removable Brew Basket: 3 tablespoons (44 g) maximum.
7. Close Brew Basket Lid. Place Brew Basket in Funnel.
8. Close Lid and snap in place to latch Lid closed.
9. Use Cup Rest for a cup/mug, or remove Cup Rest for a travel mug.
10. Press BREW NOW I/O button to start brewing. Brew indicator light will light up to show that Coffee Maker is brewing. Coffee Maker will shut off automatically when brewing is complete.
11. Unplug.
12. Brew Basket should be rinsed after every use.

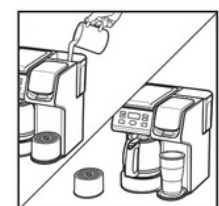
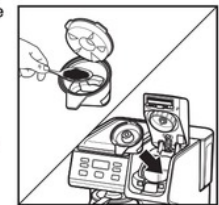
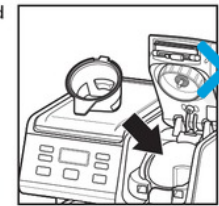

6

How to Brew a Carafe

⚠ WARNING Burn Hazard.

If filter basket overflow occurs, unplug coffee maker and allow coffee in filter basket to cool before removing filter basket. To avoid hot coffee overflowing:

When using decaffeinated coffee, do not exceed the coffee manufacturer's recommended serving amount. Use only the carafe supplied with your unit or its exact replacement.

1. Plug into outlet.
2. Lift lid. Rotate Swivel Shower Head over Water Reservoir and remove Brew Basket.
3. Place a basket-style paper filter in Brew Basket.
4. For each cup of coffee being made, place one level tablespoon (15 g) of coffee into filter.
5. Place Brew Basket into holder and lower Lid. Shower Head will go back into place when Lid is lowered.
6. Press CARAFE (☐) button.
7. Fill Carafe with up to 12 cups of cold water and pour into Carafe Water Reservoir.
8. Place Carafe, with its lid attached, on Warming Plate.
9. Press BREW STRENGTH (☞☞) button to change strength to bold, if desired.
10. Press BREW NOW I/O button to start brewing. Brew indicator light will light up to show that Coffee Maker is on.
11. Press BREW NOW I/O button to turn off.
12. Unplug.
13. Brew Basket and Carafe should be rinsed after every use.

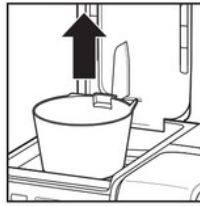

Automatic Shutoff: Automatic Shutoff feature shuts off Coffee Maker two hours after brew cycle begins.

NOTE: Unit will only brew on one side at a time.

Pause and Serve: To serve coffee during brewing cycle, remove Carafe and pour a cup. By removing Carafe, flow of coffee from bottom of Filter Basket will stop.

⚠ CAUTION Burn Hazard. The carafe must be replaced within 20 seconds of being removed to prevent overflow.

NOTE: Bold mode will require additional time to complete a brewing cycle. Coffee Maker remembers last brew option selected. If unplugged, Coffee Maker defaults to regular.

Tips for Best-Tasting Coffee

- All coffees are made from either arabica beans or robusta beans, or some combination of both. Arabica beans are slightly more expensive, but tend to produce better-tasting coffee.
- Ground coffee will become stale much faster than whole beans. If buying preground coffee, choose a package with latest expiration date or a smaller quantity.
- If grinding whole beans, set your coffee grinder on a fine/medium grind. This will yield best-tasting grounds. Try to use freshly ground coffee within about a week of grinding.
- Using a water filter, filtered water, or bottled water will yield better-tasting coffee than tap water.
- Use approximately 1 tablespoon (15 g) of grounds for each cup of coffee being made. To avoid overflow, use slightly less grounds (3/4 tablespoon [11.3 g]) when brewing decaf or flavored coffees. Also, be aware that using coffee that is ground too finely may also cause Filter Basket to overflow.
- Make sure your Coffee Maker is clean. See "Care and Cleaning" section.

7

Care and Cleaning

⚠ WARNING Shock Hazard.

Do not immerse cord, plug, or coffee maker in any liquid.

⚠ WARNING Burn Hazard.

Failure to allow coffee maker to cool down may cause hot water or coffee to spray from the piercing needle. Use caution when cleaning.

⚠ CAUTION Cut Hazard.

Removable single-serve pod holder has a sharp needle. Piercing needle on underside of lid also is sharp. Use caution when handling.

General Cleaning

1. Unplug and allow to cool.
2. Hand wash all removable parts in hot, soapy water. Rinse and dry or wash in top rack only of dishwasher. DO NOT use "SANI" setting when washing in dishwasher. "SANI" cycle temperatures could damage your product.
3. Wipe outside of Coffee Maker with a soft damp cloth.

Clogged Needle

1. Unplug and allow to cool.
2. Remove Gray Removable Needle Holder in Lid by turning counterclockwise from locked icon (🔒) to unlocked icon (🔓).
3. Bend a small paper clip. Insert tip of paper clip through hole of Piercing Needle and up into shaft of Piercing Needle to ensure grounds have been removed.
4. To replace Gray Removable Needle Holder, insert tab between lock icon (🔒) and unlock icon (🔓) and turn to clockwise to lock.



Routine Cleaning

All coffee makers should be cleaned at least once a month (once a week for areas with hard water).

To Clean Carafe Side:

1. Plug into outlet.
2. Press CARAFE (☐) button.
3. Pour 2 cups (473 ml) of plain white vinegar into Carafe Water Reservoir. Place Carafe underneath to catch vinegar.
4. Press BREW NOW I/O button once. After 30 seconds, press BREW NOW I/O button again to stop brewing and allow vinegar to clean. After 30 minutes, press BREW NOW I/O button and allow it to finish brew cycle. When brew cycle is finished, empty Carafe and rinse. Run 2-3 additional cycles, using cold tap water. Carafe side is cleaned and ready to brew coffee.
5. Unplug.

To Clean Single-Serve Side:

1. Remove Single-Serve Water Reservoir and discard water. Add 1 1/2 cups (355 ml) plain white vinegar to Reservoir and return to place.
2. Plug into outlet.
3. Press CUP SIZE (☺) button and select a mug larger than 10 ounces.
4. Pour 1 cup (273 ml) of plain white vinegar into Single-Serve Water Reservoir. Place a 15 oz. (444 ml) or larger cup or travel mug underneath to catch vinegar.
5. Select 8 oz or 10 oz size and press BREW NOW I/O button. When solution starts dispensing, press BREW NOW I/O button again to stop brewing and allow vinegar to clean. After 30 minutes, press BREW NOW I/O button and allow it to finish brew cycle. Empty Reservoir and fill with cold tap water; run 2-3 additional cycles. Unit is cleaned and ready to brew coffee.
6. Unplug.

9

Troubleshooting — Single-Serve Side

Coffee Maker will not brew/coffee not dispensing.

- Piercing Needle may be clogged. Always remove Gray Removable Needle Holder. Clean Piercing Needle in Lid of Coffee Maker as shown on page 9.
- Mineral deposits have formed. Clean Coffee Maker following directions in Care and Cleaning section.
- Too little water. Need 15 oz. (444 ml) or more.

Coffee tastes bad.

- Too much water was added or too much or too little ground coffee was added. Change ratio of water to coffee grounds or use less water with coffee pods.
- Poor coffee quality and freshness.
- Poor water quality. Use filtered or bottled water.

Coffee sediment in cup.

- Try a coarser grind of coffee, or add a #1 paper cone coffee filter to Brown Removable Brew Basket. Make sure hinged Lid is closed on Brown Removable Brew Basket.

Water on counter under unit.

- Overfilled Water Reservoir. Do not add more than 40 oz. (1.2 l) of water. Some mugs/cups do not pour cleanly and can dribble water down side of cup and onto counter.

Control Panel Notifications:

- CLEAN: Coffee Maker needs to be cleaned. See page 9.
- CLOSE LID: Coffee Maker Lid is not closed properly. Push Lid down to lock into place.
- NEEDLE: Needle is clogged. Always remove Gray Removable Needle Holder and follow "Clogged Needle" instructions on page 9.
- H2O FIL: Not enough water. Add water to Water Reservoir and press BREW NOW // button to clear Display. Press BREW NOW // button to restart brew cycle.
- OVER: Allow Coffee Maker to cool for 15 minutes. Make sure there is water in Water Reservoir, and then press BREW NOW // button to restart brewing cycle.

Coffee overflows from Brew Basket.

- Use Removable Brew Basket with Lid for ground coffee.
- Use a lesser amount of ground coffee. 3 tablespoons (44 ml) is maximum amount of grounds to brew.
- When using whole bean coffee, a standard automatic drip coffee grind will yield best results. Be careful not to overgrind, since very finely ground coffee can cause overflow.
- Black Seal around Needle in Removable Needle Holder is missing. Carefully place seal around needle and push until in place.

Coffee overflows from travel mug or regular mug.

- Empty mug after manually stopping brew cycle. Press BREW NOW // button to start a new brewing cycle.

Coffee single-serve pod bursts.

- There is variability in single-serve pod manufacturing process which causes some types of single-serve pods to be weaker at seams so foil seal fails. Try a different brand.

Delay Brew feature does not work with Single-Serve side.

- Delay Brew feature is not designed to work with Single-Serve side. Program mode is for Carafe side only.

10

Troubleshooting — Carafe Side

Longer than normal brew time.

- Bold brewing cycle takes longer to brew to produce a rich, full bodied cup of coffee.
- Mineral deposits can build up in pump of your Coffee Maker. Periodic cleaning of inside of unit is recommended. More frequent cleaning may be necessary, depending on hardness of your water. See "Care and Cleaning" section. NOTE: Do not disassemble unit.

Brew Basket overflows or coffee brews slowly.

- Excessive amounts of ground coffee.
- Decaffeinated and/or coffee ground too finely can cause overflow. Use slightly less grounds when brewing decaffeinated, flavored, or finely ground coffee. Or use medium ground coffee.
- Coffee Maker needs cleaning. See Care and Cleaning on page 9. If using a paper filter:
 - Coffee grounds between paper filter and Brew Basket.
 - Paper filter not open and in proper position.
 - Rinse Brew Basket before inserting paper filter so edges will remain pressed against sides of Basket.
 - Poor-quality paper filter.

Coffee leaks onto base.

- Carafe removed from Warming Plate for more than 20 seconds during brewing cycle.

Coffee tastes bad.

- Coffee Maker needs cleaning. See Care and Cleaning on page 9.
- Coffee ground too coarsely or too finely. Use medium ground coffee.
- Coffee-to-water ratio unbalanced. Adjust for personal preference.
- Poor coffee quality and freshness.
- Poor water quality. Use filtered or bottled water.

Coffee sediment in cup.

- Use a high-quality, basket-style paper filter.

Coffee not brewing or unit will not turn on.

- Carafe not positioned on Warming Plate.
- Water Reservoir is empty.
- Unit is unplugged.
- Power outage.
- Power surge. Unplug; then plug unit back in.
- Clock requires reset after power outage.
- BREW NOW // button was not pressed. Press BREW NOW // button.

11



Washer (LG WT7150CW) and Dryer (LG DLE7150W)

- **Washer:** Online Manual <https://gscs-b2c.lge.com/downloadFile?fileId=VAkelSTvcufRC2FB5chg>
 1. Open the washer door and load your laundry.
 2. Open the lid and the detergent dispenser will be in the back and will need to be pulled out.
 3. Select your wash cycle using the touch capacitive buttons.
 4. Press start to begin the cycle.
- **Dryer:** Online Manual <https://gscs-b2c.lge.com/downloadFile?fileId=GIJ7or1teiT2JJ3nwH47lg>
 1. Transfer wet laundry into the dryer.
 2. Clean the lint filter before starting.
 3. Select your drying cycle using the touchpad.
 4. Press start to begin the drying process.

Control Panel

Control Panel Features

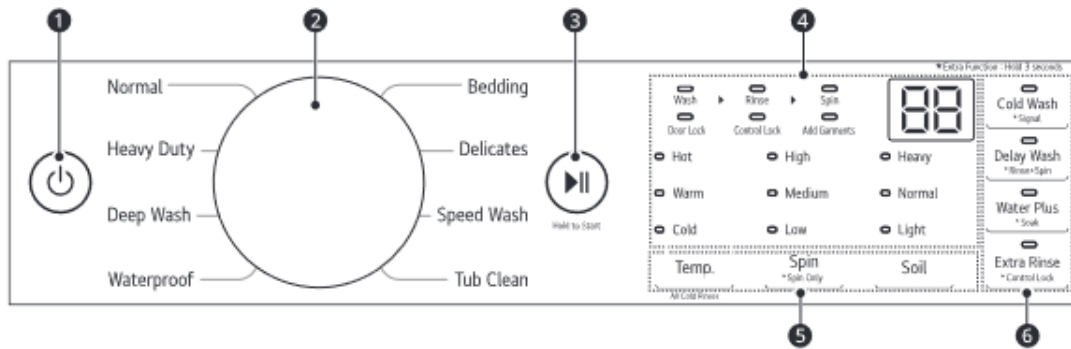

1 Power On/Off Button

- Press this button to turn the washer on or off.
- Pressing this button during a cycle will cancel that cycle and any load settings will be lost.
- The door will unlock after a brief pause.

NOTE

- If there is any water remaining in the drum after the washer shuts off, it will drain after a delay. The washer can be restarted at any time before the drain begins. However, once the water begins to drain, all functions will be suspended until the water has been completely drained and the washer shuts off.

2 Cycle Selector Knob

- Turn this knob to select the desired cycle.
- Once the desired cycle has been selected, the standard presets will appear in the display. These settings can be adjusted using the **Cycle Modifier** buttons at any time before starting the cycle.

3 Start/Pause Button

- Press this button to start the selected cycle.
- If the washer is running, use this button to pause the cycle without losing the current settings.

NOTE

- If the **Start/Pause** button is not pressed to start the selected cycle, after a delay the washer automatically turns off and all cycle settings are lost. Any water remaining in the drum will be drained.

4 Time and Status Display

5 Cycle Modifier Buttons

- Use these buttons to adjust the wash temperature, spin speed and soil level settings for the selected cycle.
- The current settings are shown in the display.
- Press the button for that option to select other settings.

6 Option and Extra Function Buttons

- These buttons allow you to select additional cycle options. Certain buttons also allow you to activate special functions by pressing and holding the button for **3 seconds**.

Wash Cycles

The wash cycles are designed for specific types of wash loads. Select the cycle that best matches the load contents for maximum wash performance and fabric care.

See the **Sorting Laundry** section for best results, and follow the fabric care labels on your garments. For a guide to fabric care symbols, see the **Sorting Laundry** section.

Cycle Guide

Turn the knob or press the button to select the desired cycle. When you select a wash cycle, the light for the corresponding wash cycle will turn on.

NOTE

- Whenever load weights are mentioned, assume 1 lb (0.45 kg) = 1 thick bath towel (dry).

Cycle	Normal	
Description	Use to wash all normal items such as cotton, linen, shirts, jeans or mixed loads, except delicate fabrics such as wool or silk. <ul style="list-style-type: none"> • Pressing the Start/Pause button without selecting a cycle will cause the Normal cycle to begin immediately, using the default settings. 	
Wash Temp.	Default: Warm	Available: All
Spin Speed	Default: High	Available: High, Medium
Soil Level	Default: Normal	Available: All

Cycle	Heavy Duty	
Description	Suitable for washing heavily soiled laundry, such as cotton fabrics, using more powerful wash motions. <ul style="list-style-type: none"> • When washing large loads, there will be brief periods of 2 minutes or more without agitation. These soak periods are part of the cycle's design, and are normal. 	
Wash Temp.	Default: Warm	Available: All
Spin Speed	Default: High	Available: All
Soil Level	Default: Heavy	Available: All

Cycle	Deep Wash	
Description	Provides additional water and washes heavily soiled mixed items, except delicate fabrics.	
Wash Temp.	Default: Warm	Available: All
Spin Speed	Default: Medium	Available: All
Soil Level	Default: Normal	Available: All

Cycle	Waterproof	
Description	Suitable for washing waterproof items such as water resistant clothing, mattress covers, outdoor clothes, and plastic mats. (less than 14 lb)	
	NOTE <ul style="list-style-type: none"> • Do not use any other wash cycle to wash waterproof items. • Do not use this cycle to wash a mixed load of waterproof and non-waterproof items. • Check the fabric care label on the garments before using this cycle. • Do not wash other fabrics using this cycle. 	
Wash Temp.	Default: Warm	Available: Warm, Cold
Spin Speed	Default: Medium	Available: Medium, Low
Soil Level	Default: Light	Available: All

Cycle	Bedding	
Description	Suitable for washing blankets or bulky items which have difficulty absorbing water, such as pillows, blankets, comforters, sheets or pet bedding.	
	<ul style="list-style-type: none"> • Do not use this cycle to wash a mixed load of bedding and non-bedding items. • Do not mix large/bulky items with smaller articles of clothing. • Do not wash excessively large items. If large/bulky items do not fit easily into the tub, there may not be enough room for them to move during washing. 	
Wash Temp.	Default: Warm	Available: All
Spin Speed	Default: Medium	Available: All
Soil Level	Default: Normal	Available: All

Cycle	Delicates	
Description	Suitable for washing dress shirts/blouses, nylons, lingerie, or sheer and lacy clothes which can easily be damaged. (less than 8 lb)	
Wash Temp.	Default: Cold	Available: Warm, Cold
Spin Speed	Default: Medium	Available: Medium, Low
Soil Level	Default: Light	Available: All

Cycle	Speed Wash	
Description	Use this option to quickly wash lightly soiled clothing and small loads. For high wash and rinse efficiency, wash small loads of 2-3 lightly soiled garments.	
	<ul style="list-style-type: none"> • Use very little detergent in this cycle. To add an extra rinse, use the Extra Rinse button. 	
Wash Temp.	Default: Warm	Available: Warm, Cold
Spin Speed	Default: High	Available: All
Soil Level	Default: Light	Available: All

Cycle	Tub Clean
Description	This is a special cycle designed to clean the inside of the washer.

Available Options

NOTE

- The **Delay Wash** can be selected for every cycle in this table.
- Adding the **Water Plus** option to the **Normal** cycle will automatically change the cycle to the **Deep Wash** cycle.

Cycle	Cold Wash	Extra Rinse	Water Plus	Soak
Normal	●	●	●	●
Heavy Duty		●	●	●
Deep Wash		●	●	●
Waterproof		●	●	
Bedding	●	●		●
Delicates		●	●	●
Speed Wash		●	●	●

Control Panel

Control Panel Features

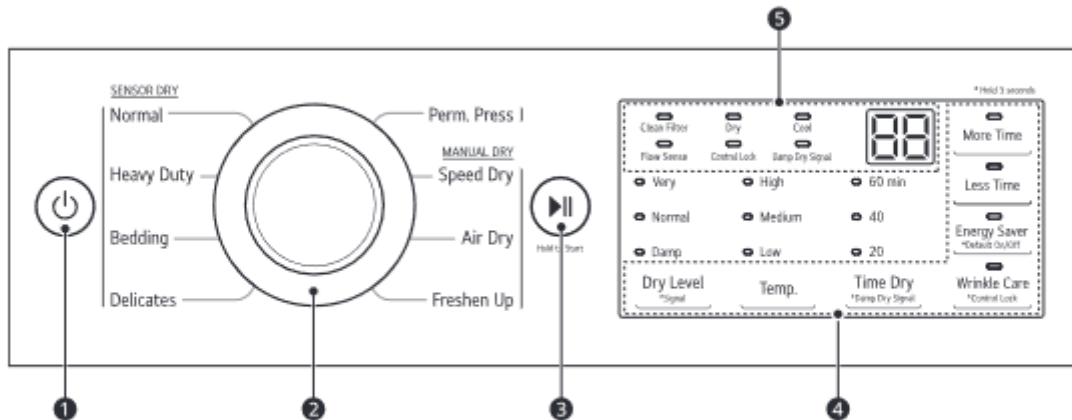

1 Power Button

- Press the button to turn the appliance on. Press again to turn the appliance off.

NOTE

- Pressing the **Power** button during a cycle will cancel that cycle, and any load settings will be lost.

2 Cycle Selector Knob

- Turn this knob to select the desired cycle. Once the desired cycle has been selected, the standard presets will be shown in the display. On Manual Dry cycles, these settings can be adjusted using the cycle modifier buttons anytime before starting the cycle.

3 Start/Pause Button

- Press this button to start the selected cycle. If the appliance is running, use this button to pause the cycle without losing the current settings.

NOTE

- If you do not press the **Start/Pause** button to resume a cycle within a certain time, the appliance turns off automatically and all cycle settings are lost.

4 Extra Options and Functions / Cycle Modifier Buttons

- Use these buttons to select the desired options for the selected cycle. Not all options are available for each cycle.

5 Time and Status Display

- The display shows the settings, estimated time remaining, options, and status messages for the appliance. When the appliance is turned on, the default settings in the display will illuminate.

Before Use

WARNING

- To reduce the risk of fire, electric shock, or injury to persons, read the **IMPORTANT SAFETY INSTRUCTIONS** before operating this appliance.

Operation Overview

1 Clean the Lint Filter

- If the lint filter has not already been cleaned, lift out the filter and remove the lint from the last load. This will help ensure the fastest and most efficient drying performance. Make sure to reinstall the filter, pressing down until it clicks firmly into place.

2 Load the Dryer

- Make sure that clothing is pushed entirely into the drum and away from the door seal area. Clothing that gets stuck between the door and seal may be damaged or damage the seal.
- If the load is extra large, you may need to divide it into smaller loads for proper performance and fabric care.
- All strings and attached belts of clothes should be well tied and secured before being put into the drum.

3 Turn on the Dryer

- Press the **Power** button to turn on the dryer. The cycle LEDs will illuminate and a chime will sound.

4 Select a Cycle

- Turn the cycle selector knob in either direction until the LED for the desired cycle is on. The preset temperature, dry level, and option settings for that cycle will be shown.
- Pressing the **Start/Pause** button without selecting a cycle immediately starts the **Normal** cycle with the default settings. Select the **Normal** cycle to change the default settings.

5 Adjust Settings

Default settings for the selected cycle can now be changed, if desired, using the cycle modifier and option buttons.

- Not all modifiers and options are available on all cycles. A different chime will sound and the LED will not come on if the selection is not allowed.

6 Begin Cycle

- Press the **Start/Pause** button to begin the cycle. The cycle can be paused at any time either by opening the door or by pressing the **Start/Pause** button.
- If the **Start/Pause** button is not pressed within a certain time, the dryer shuts off and all settings are lost.

7 End of Cycle

- When the cycle is finished, the chime will sound. Immediately remove your clothing from the dryer to reduce wrinkling. If **Wrinkle Care** is selected, the dryer will tumble briefly every few minutes to help prevent wrinkles from setting in the clothes.

Check the Lint Filter Before Every Load

Always make sure the lint filter  is clean before starting a new load; a clogged lint filter will increase drying time. To clean, pull the lint filter straight up and roll any lint off the filter with your

fingers. Push the lint filter firmly back into place. See **Regular Cleaning** for more information.

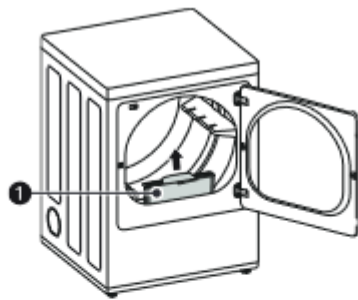

Always ensure that the lint filter is properly installed before running the dryer. Running the dryer with a loose or missing lint filter will damage the dryer and articles in the dryer.

Loading the Dryer

NOTE

- For the best drying performance and most efficient energy usage, do not overload the appliance.

General Tips

- Combine large and small items in the same load.
- Use mesh laundry bags to separate clothes with zippers, hooks, straps, and drawstrings to prevent them from catching on or tangling with other clothes or damaging the lint filter.

NOTE

- Damp clothes will expand as they dry. Do not overload the dryer; clothes require room to tumble and dry properly.

Grouping Similar Items

For the best drying results, and to reduce the possibility of damage to clothing, sort clothes into loads that can be dried with the same drying cycle.

Different fabrics have different care requirements, and some fabrics will dry more quickly than others.

Woolen Items

- Always follow fabric care labels before drying woolen items in a dryer. After the cycle, the items may still be damp. Do not repeat the cycle. Pull the items to their original shape if needed and lay them flat to finish drying.

Woven and Loopknit Materials

- Some woven and loopknit materials may shrink, depending on quality.

Permanent Press and Synthetics

- Do not overload your dryer. Take out permanent press items as soon as the dryer stops to reduce wrinkles.

Baby Clothes and Nightgowns

- Always check the manufacturer's instructions.

Rubber and Plastics

- Do not dry any items made from or containing rubber or plastics such as:
 - Aprons, bibs and chair covers
 - Curtains and tablecloths
 - Bath mats

Fiberglass

- Do not dry fiberglass articles in your dryer. Glass particles left in the dryer could be picked up by your clothes the next time you use the dryer and irritate your skin.

Fabric Care Labels

- Sort and dry laundry according to care labels, size, and fabric type. Do not overload the dryer. This will save energy and time and give the best drying performance.

Fabric Care Labels

Many articles of clothing include a fabric care label. Using the chart below, adjust the cycle and option selections to care for your clothing according to the manufacturer's recommendations.

Tumble Dry	
Label	Directions
	Dry
	Normal
	Permanent Press / Wrinkle Resistant
	Gentle / Delicate

Grill

Short Instructional Video: <https://www.youtube.com/watch?v=RMu8GH7tWRY>

A black bin is provided for essential tools and equipment for the grill. This is on the deck and is also labeled.

- **Operation and Safety:**

1. Open the grill lid before lighting it.
2. Add charcoal and lighter fluid.
4. Always monitor the grill while in use and keep flammable materials away.
5. Allow charcoal to burn out when grilling is complete.

Shower

- **Adjusting Water Temperature:**







1. To turn the water on, with the handle or knob designated for water flow, move the handle to the 12:00 position.
2. Adjust the temperature by turning the temperature control knob or handle.
3. Adjust to your desired temperature before entering the shower (move the handle to the right to get warm, or to the left for cold).
4. To start the shower head, pull up on the lever found on the tub spout.



Electric Fireplace (Simpli Fire)

Enjoy the warmth and ambiance of our Simpli Fire electric fireplace without the hassle of a real fire. Here's how to operate it:



ICON	TITLE	FUNCTION	REMOTE LCD DISPLAY	FIREPLACE RESPONSE
	POWER	The POWER button will turn the fireplace on. It will also put the fireplace in a standby mode. This will turn off all functions at once but will hold the settings in memory except Heater function. The unit will turn on at the same settings by pressing the power button again.	LCD illuminates and displays flame status icon and temperature set point.	Fireplace emits single audible beep to confirm command to transition to ON or STANDBY state
	FLAME	By pressing the FLAME button, the unit will cycle through four flame effects.	LCD illuminates and displays flame status icon.	Fireplace emits single audible beep to confirm command to transition between four FLAME states.
	HEATER	Press Heater button once 750W heater turns on. Press Heater button twice 1500W turns on, Press Heater button three times, turns off heater.	LCD illuminates and displays heater status icon.	Fireplace emits signal audible beep to confirm command to transition between HEATER states. Fireplace displays one red LED for 8 seconds to confirm low heater command. Fireplace displays two red LED for 8 seconds to confirm high heater command.
	THERMOSTAT	Pressing the Temperature button adjusts the heaters response to the ambient temperature conditions in the room. Temperature adjusts from 16 °C - 28 °C (61 °F - 82 °F). Power button must be on to set from °C to °F. Hold for 3 seconds and the LCD display from °C to °F.	Remote displays the temperature. If in Stand-by mode, temperature displays but cannot be adjusted.	Fireplace emits single audible beep to confirm command to change desired temperature setpoint.
	TIMER	Pressing the Timer button sets the time desired for the fireplace to run. The Timer can be set from .5 hour up to 9 hours in 1 hour increments.	Remote will display the time setting selected. If in Stand-by mode time will display but cannot be adjusted.	Fireplace emits single audible beep to confirm command to transition between four FLAME states.
	LIGHT	Pressing the spotlight button will switch the spotlight on and off.	No indicator.	Fireplace will emit one audible beep as it transitions between spotlight on and off states.

- **Using the Remote Control:**

1. The Simpli Fire electric fireplace comes with a remote control for easy operation.
2. Use the remote to turn the fireplace on or off and adjust the temperature.
3. To adjust the heat setting, press the temperature control buttons until you reach your desired warmth.



- **Safety and Maintenance:**

1. Ensure the fireplace's air intake and outlet vents are not blocked to prevent overheating.
2. The surface of the fireplace may become hot during use. Avoid touching the glass or metal parts when the heater is on.
3. When not in use, turn the fireplace off using the remote control.

Stove (Whirlpool W11476789 A)

- **Operation:**

1. Turn the corresponding knob to the burner you wish to use.
2. Lightly push and turn the knob to your desired setting (low, medium, high).
3. Be cautious of the stove range when you see the "hot surface" indicator light.



FEATURE GUIDE

This manual covers several models. Your model may have some or all of the items listed. Refer to this manual or the Frequently Asked Questions section of our website at www.whirlpool.com for more detailed instructions. In Canada, reference the Customer Service section at www.whirlpool.ca.



⚠ WARNING

Food Poisoning Hazard

Do not let food sit in oven more than one hour before or after cooking.

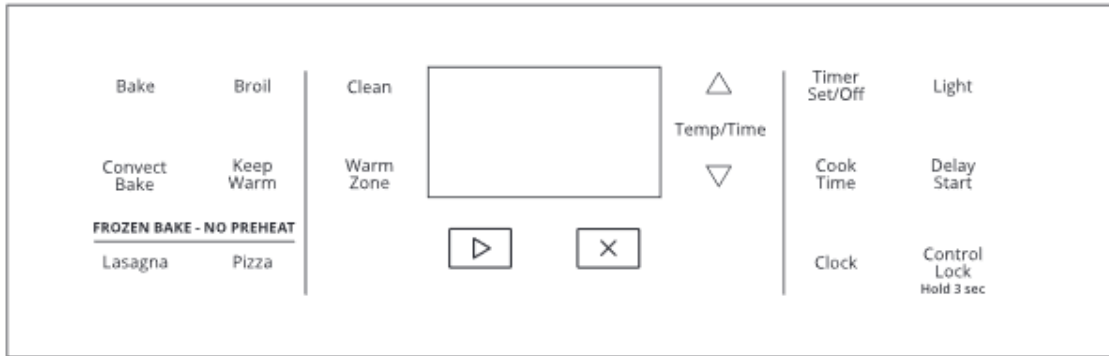
Doing so can result in food poisoning or sickness.



Keypad	Feature	Instructions
CLOCK	Clock	The Clock uses a 12-hour cycle. <ol style="list-style-type: none"> 1. Check that the oven is off. 2. Press CLOCK. 3. Press the Temp/Time up or down arrow keypad to set the hours. Press CLOCK to switch to the minutes. Press the Temp/Time up or down arrow keypad to set the minutes. 4. Press CLOCK or the Start keypad.
LIGHT	Oven cavity light	While the oven door is closed, press LIGHT to turn the light on and off. The oven light will come on when the oven door is opened. The oven light will not come on during the Self-Cleaning cycle.
TIMER SET/OFF	Oven timer	The Timer can be set in hours or minutes up to 9 hours and 59 minutes. <ol style="list-style-type: none"> 1. Press TIMER SET/OFF. 2. Press the Temp/Time up or down arrow keypad to set the length of time. 3. Press the Start keypad to begin the countdown. If enabled, end-of-cycle tones will sound at end of countdown. 4. Press TIMER SET/OFF to cancel the Timer. Do not press the Cancel keypad because the oven will turn off.
Start 	Cooking start	The Start keypad begins any oven function. If the Start keypad is not pressed within 10 seconds, a tone will sound and the Start keypad will blink until pressed or canceled. If Start is not pressed within 30 seconds after pressing a keypad, the function is canceled and the time of day is displayed.
Cancel 	Range function	The Cancel keypad stops any function except the Timer and Oven Control Lockout.
TEMP/TIME	Temperature and time adjust	The Temp/Time up and down arrow keypads are used to adjust time and temperature settings.

Keypad	Feature	Instructions
BAKE	Baking and roasting	<ol style="list-style-type: none"> 1. Press BAKE. 2. Press the Temp/Time up or down arrow keypad until desired temperature is reached. A tone will sound if the minimum or maximum temperature is reached. 3. Press the Start keypad. 4. To change the temperature, repeat Step 2. Press the Start keypad. 5. Press the Cancel keypad when finished. <p>NOTE: The convection fan will shut off when the oven door is opened. If the oven door remains open for too long, the heating elements will shut off until the oven door is closed. All timers, including any active Cook Time or Timed Cook functions, will continue to count down.</p>
CONVECT BAKE	Convection baking and roasting	<ol style="list-style-type: none"> 1. Press CONVECT BAKE. 2. Press the Temp/Time up or down arrow keypad until desired temperature is reached. A tone will sound if the minimum or maximum temperature is reached. 3. Press the Start keypad. 4. To change the temperature, repeat Step 2. Press the Start keypad. 5. Press the Cancel keypad when finished. <p>NOTE: The convection fan will shut off when the oven door is opened. If the oven door remains open for too long, the heating elements will shut off until the oven door is closed. All timers, including any active Cook Time or Timed Cook functions, will continue to count down.</p>
FROZEN BAKE	Prepackaged food	<ol style="list-style-type: none"> 1. Position the food on a flat rack in the oven on rack position 3 or 4. See the "Positioning Racks and Bakeware" section. NOTE: Cook only 1 package of frozen food at a time when using Frozen Bake™ Technology. 2. Press FROZEN BAKE LASAGNA or PIZZA. 3. Press the Temp/Time up or down arrow keypad to set the temperature as recommended on the food packaging. 4. Press COOK TIME. 5. Press the Temp/Time up or down arrow keypad to set the maximum cook time as recommended on the food packaging. 6. Press the Start keypad. The range will calculate the best cook time based on the current oven temperature. NOTE: The cook time that appears in the display is the estimated required cook time as calculated by the oven control. It may be different than the time you entered. A beep will alert you to check the food's doneness with at least 2 minutes remaining on the timer. Follow the prompts on the display to select more time if desired. 7. Press the Start keypad to start the calculated time. 8. At the end of the cook time, a beep will alert you to check the food's doneness. When "End" is displayed and Ⓢ is flashing, you can add more time, if desired. Press the up or down arrow keypad to set the time, then press START. If more time is not added, the bake element will turn off. NOTE: Pressing Cancel will exit the Frozen Bake™ cycle. 9. Press the Cancel keypad when finished. <p>NOTE: The convection fan will shut off when the oven door is opened. If the oven door remains open for too long, the heating elements will shut off until the oven door is closed. All timers, including any active Cook Time or Timed Cook functions, will continue to count down.</p>
BROIL	Broiling	<ol style="list-style-type: none"> 1. Press BROIL. 2. Press the Temp/Time up or down arrow keypad until desired temperature is reached. A tone will sound if the minimum or maximum temperature is reached. 3. Press the Start keypad. 4. Preheat the oven for two minutes, unless otherwise recommended by recipe. Position cookware in the oven and close the oven door. 5. To change the temperature, repeat Step 2 and press the Start keypad. 6. Press the Cancel keypad when finished. <p>NOTE: The convection fan will shut off when the oven door is opened. If the oven door remains open for too long, the heating elements will shut off until the oven door is closed. All timers, including any active Cook Time or Timed Cook functions, will continue to count down.</p>

Keypad	Feature	Instructions
KEEP WARM	Hold warm	<p>Food must be at serving temperature before placing it in the warmed oven.</p> <ol style="list-style-type: none"> 1. Press KEEP WARM. 2. Temperature is set at 170°F (75°C). Press the Temp/Time up or down arrow keypad until desired temperature is reached. A tone will sound if the minimum or maximum temperature is reached. 3. Press the Start keypad. 4. Press the Cancel keypad when finished. <p>NOTE: The convection fan will shut off when the oven door is opened. If the oven door remains open for too long, the heating elements will shut off until the oven door is closed. All timers, including any active Cook Time or Timed Cook functions, will continue to count down.</p>
WARM ZONE	Warming zone	<p>Press WARM ZONE to select the warming element on the cooktop. Press the Start keypad. Press WARM ZONE again to turn off the warming element.</p>
DELAY START	Delayed start	<p>Delay Start is used to enter the starting time for an oven function with a delayed start. Delay Start should not be used for foods such as breads and cakes because they may not bake properly.</p> <p>To set a Timed Cook or a Delayed Timed Cook, see "Cook Time" section.</p>
COOK TIME	Timed cooking	<p>Cook Time allows the oven to be set to turn on at a certain time of day, cook for a set length of time, and/or shut off automatically.</p> <p>To set a Timed Cook or a Delayed Timed Cook, see "Cook Time" section.</p>
CLEAN	Self-Cleaning cycle	<p>See the "Self-Cleaning Cycle" section.</p>
CONTROL LOCK (Hold 3 sec)	Oven and cooktop control lockout	<ol style="list-style-type: none"> 1. Check that the oven and cooktop are off. 2. Press and hold CONTROL LOCK for 3 seconds. 3. A tone will sound and a lock will be displayed. 4. Repeat to unlock. No keypads will function with the controls locked.

Refrigerator (Whirlpool 22MSSA)

Full Manual: <https://www.whirlpool.com/content/dam/global/documents/201304/owners-manual-W10439277-RevC.pdf>

- **Features:**

1. Filtered water (Also available to the right side of the sink)
2. Ice Maker

REFRIGERATOR USE

Using the Controls

The refrigerator and freezer controls are located on the dispenser panel.

IMPORTANT: The display screen on the dispenser control panel will turn off automatically and enter "sleep" mode when the control buttons and dispenser pads have not been used for 2 minutes or more. While in "sleep" mode, the first press of a control button will only reactivate the display screen, without changing any settings.

- Touch any control button on the dispenser panel to activate the display screen. The home screen will appear as shown.

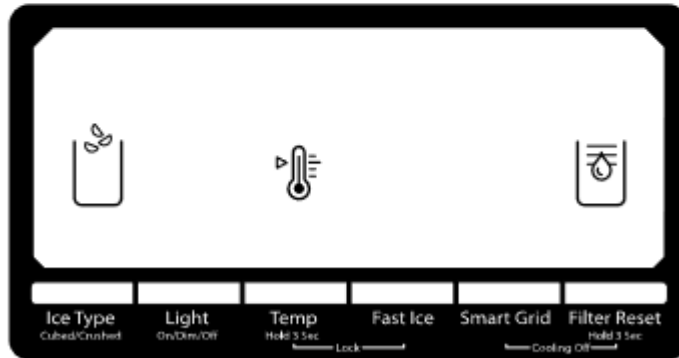

Adjusting the Controls

For your convenience, your refrigerator and freezer controls are preset at the factory. When you first install your refrigerator, make sure that the controls are still set to the "mid-settings." The factory recommended set points are 37°F (3°C) for the refrigerator and 0°F (-18°C) for the freezer.

IMPORTANT:

- Wait 24 hours before you put food into the refrigerator. If you add food before the refrigerator has cooled completely, your food may spoil.

NOTE: Adjusting the set points to a colder than recommended setting will not cool the compartments any faster.

- If the temperature is too warm or too cold in the refrigerator or freezer, first check the air vents to be sure they are not blocked before adjusting the controls.
- The preset settings should be correct for normal household usage. The controls are set correctly when milk or juice is as cold as you like and when ice cream is firm.
- Wait at least 24 hours between adjustments. Recheck the temperatures before other adjustments are made.

To view and adjust the set points, press and hold the TEMP button for 3 seconds. When adjust mode is activated, adjusting information will appear on the display screen.



NOTE: To view Celsius temperatures, press the LIGHT button when adjust mode is activated. To return the display setting to Fahrenheit, press LIGHT again.

- When adjust mode is activated, the display screen shows the refrigerator set point and "FRIDGE" appears.
- Press SMART GRID to raise the set point, or press FAST ICE to lower the set point.
- When you have finished viewing (and adjusting if desired) the refrigerator set point, press TEMP to change the display to show the freezer set point. When the zone has been changed, "FREEZER" appears on the display screen.
- Press SMART GRID to raise the set point, or press FAST ICE to lower the set point.
- When you have finished viewing (and adjusting if desired) both the refrigerator and freezer set points, press FILTER to save the settings.

NOTE: To exit without saving changes, press ICE TYPE at any time while in adjust mode, or allow about 60 seconds of inactivity and adjust mode will turn off automatically.

When adjusting temperature set points, use the following chart as a guide.

CONDITION:	TEMPERATURE ADJUSTMENT:
REFRIGERATOR too cold	REFRIGERATOR Setting 1° higher
REFRIGERATOR too warm	REFRIGERATOR Setting 1° lower
FREEZER too cold	FREEZER Setting 1° higher
FREEZER too warm / Too little ice	FREEZER Setting 1° lower

The set point range for the refrigerator is 33°F to 45°F (0°C to 7°C). The set point range for the freezer is -5°F to 5°F (-21°C to -15°C).

Cooling On/Off

Your refrigerator and freezer will not cool when cooling is turned off.

- To turn cooling off, press and hold the SMART GRID and FILTER buttons at the same time for 3 seconds.
IMPORTANT: To avoid unintentionally locking the dispenser or changing other settings, be sure to press both buttons at exactly the same time.
When cooling is off, "COOLING OFF" will appear on the display screen.
- Press and hold SMART GRID and FILTER for 3 seconds again to turn cooling back on.

Smart Grid

See "Smart Refrigerator Features" for information about setting up Smart Grid functionality, turning it on and off, receiving important notifications, and taking advantage of available features.

Delay Ice

For information about the Delay Ice feature that is associated with Smart Grid functionality, see "Smart Refrigerator Features."

Additional Features

Fast Ice

The Fast Ice feature assists with temporary periods of heavy ice use by increasing ice production over a 24-hour period.

IMPORTANT: This feature only works if the ice maker is turned on. See "Ice Maker and Storage Bin."

- Press FAST ICE to turn on the Fast Ice feature. When the feature is on, the Fast Ice icon will appear on the dispenser display screen. The Fast Ice setting will remain on for 24 hours unless manually turned off.



- To manually turn off the Fast Ice feature, press FAST ICE again or adjust the freezer temperature set point. The Fast Ice icon will disappear when the feature is off.

NOTE: If increased ice production is desired at all times, change the freezer set point to a lower setting. Setting the freezer to a colder temperature may make some foods, such as ice cream, harder.

Door Ajar Alarm

The Door Ajar Alarm feature sounds an alarm when the refrigerator or freezer door is open for 5 minutes and the product cooling is turned on. The alarm will repeat every 2 minutes. Close both doors to turn it off. The feature then resets and will reactivate when either door is left open again for 5 minutes.

NOTE: To mute the audible alarm while keeping the doors open, such as while cleaning the inside of the refrigerator, press any button on the control panel. The alarm sound will be temporarily turned off, but the Door Ajar icon will still be displayed on the dispenser control panel.



Convertible Drawer Temperature Control

(on some models)

The control can be adjusted to properly chill meats or vegetables. The air inside the pan is cooled to avoid "spot" freezing and can be set to keep meats at the National Livestock and Meat Board recommended storage temperatures of 28° to 32°F (-2° to 0°C).

To store meat:

Set the control to one of the three MEAT settings to store meat at its optimal storage temperature.

To store vegetables:

Set the control to VEG to store vegetables at their optimal storage temperatures.

NOTE: If food starts to freeze, move the control to the right (less cold), toward the VEG setting. Remember to wait 24 hours between adjustments.

Crisper Humidity Control

(on some models)

You can control the amount of humidity in the moisture-sealed crisper. Adjust the control to any setting between LOW and HIGH.

LOW (open) for best storage of fruits and vegetables with skins.

HIGH (closed) for best storage of fresh, leafy vegetables.

Chilled Door Bin (on some models)

Cool air from the freezer is directed to the refrigerator door bin directly beneath the vents.

NOTE: The dairy compartment and can rack are not associated with the Chilled Door Bin feature.

Chilled Door Bin Control

The chilled door bin control is located on the left-hand side of the refrigerator compartment.

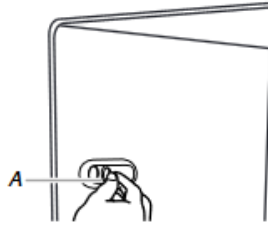

A. Chilled door bin control

- Slide the door chill control to the left to reduce the flow of cold air to the bin and make it less cold.
- Slide the door chill control to the right to increase the flow of cold air to the bin and make it colder.

Water and Ice Dispensers

NOTES:

- The dispensing system will not operate when either door (refrigerator or freezer) is open.
- Allow 24 hours for the refrigerator to cool down and chill water.
- Allow 24 hours to produce the first batch of ice. Discard the first three batches of ice produced. Wait 72 hours for full ice production.
- The display screen on the dispenser control panel will turn off automatically and enter "sleep" mode when the control buttons and dispenser pads have not been used for 2 minutes or more. While in "sleep" mode, the first press of a control button will only reactivate the display screen, without changing any settings.

Flush the Water System

Air in the water dispensing system can cause the water dispenser to drip. After connecting the refrigerator to a water source or replacing the water filter, flush the water system. Flushing the water dispensing system forces air from the water line and filter, and prepares the water filter for use.

NOTE: As air is cleared from the system, water may spurt out of the dispenser.

1. Using a sturdy container, depress and hold the water dispenser pad for 5 seconds, then release it for 5 seconds.
2. Repeat Step 1 until water begins to flow.
3. Once water begins to flow, continue depressing and releasing the dispenser pad (5 seconds on, 5 seconds off) until a total of 3 gal. (12 L) has been dispensed.

Additional flushing may be required in some households.

The Water Dispenser

IMPORTANT:

- Dispense at least 1 qt (1 L) of water every week to maintain a fresh supply.
- If the flow of water from the dispenser decreases, it could be caused by low water pressure.
 - With the water filter removed, dispense 1 cup (237 mL) of water. If 1 cup of water is dispensed in 8 seconds or less, the water pressure to the refrigerator meets the minimum requirement.
 - If it takes longer than 8 seconds to dispense 1 cup of water, the water pressure to the refrigerator is lower than recommended. See "Water Supply Requirements" or "Problem Solver" for suggestions.

To Dispense Water:

1. Press a sturdy glass against the water dispenser pad. Hold the glass close to the water dispenser spout to ensure that the water dispenses into the glass.

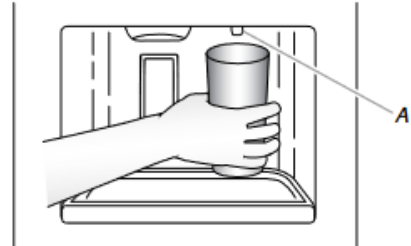

A. Water dispenser spout

2. Remove the glass to stop dispensing.

The Ice Dispenser

Ice dispenses from the ice maker storage bin in the freezer when the dispenser pad is pressed. To turn off the ice maker, see "Ice Maker and Storage Bin."

Your ice maker can produce both crushed and cubed ice. Before dispensing ice, select which type of ice you prefer by pressing the ICE TYPE button.

The display screen indicates which type of ice is selected.

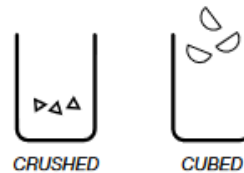

For crushed ice, cubes are crushed before being dispensed. This may cause a slight delay when dispensing crushed ice. Noise from the ice crusher is normal, and pieces of ice may vary in size. When changing from crushed to cubed, a few ounces of crushed ice will be dispensed along with the first cubes.

To Dispense Ice:

1. Make sure the desired type of ice is selected. To switch between cubed and crushed, press ICE TYPE.

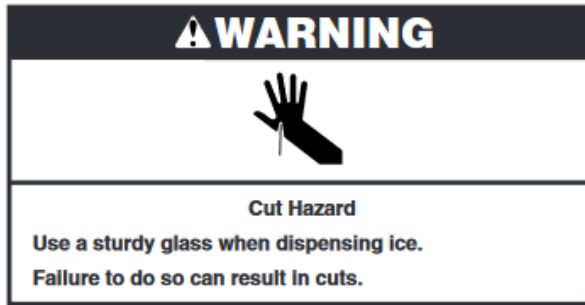

2. Press a sturdy glass against the ice dispenser pad. Hold the glass close to the ice guide to ensure that the ice dispenses into the glass.

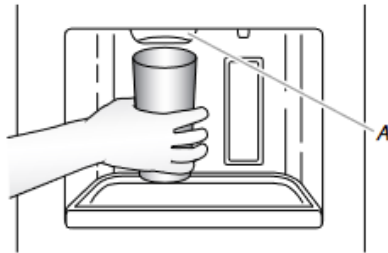

A. Ice guide

IMPORTANT: You do not need to apply a lot of pressure to the pad in order to activate the ice dispenser. Pressing hard will not make the ice dispense faster or in greater quantities.

3. Remove the glass to stop dispensing.

NOTE: Ice may continue to dispense for several seconds after removing the glass from the pad. The dispenser may continue to make noise for a few seconds after dispensing.

The Dispenser Light

When you use the dispenser, the light will automatically turn on. If you want the light to be on continuously, you may choose either ON or DIM. The display screen indicates which mode is selected.

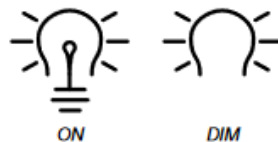

ON: Press LIGHT to turn the dispenser light on.

DIM: Press LIGHT a second time to select DIM mode. The dispenser light will remain on, but at a lower intensity.

OFF: Press LIGHT a third time to turn the dispenser light off.

The dispenser lights are LEDs that cannot be changed. If it appears that your dispenser lights are not working, see "Problem Solver" for more information.

The Dispenser Lock

The dispenser can be turned off for easy cleaning or to avoid unintentional dispensing by small children and pets.

NOTE: The lock feature does not shut off power to the refrigerator, to the ice maker, or to the dispenser light. It simply deactivates the controls and dispenser pads. To turn off the ice maker, see "Ice Maker and Storage Bin."

- Press and hold the TEMP and FAST ICE buttons at the same time for 3 seconds to lock the dispenser.

IMPORTANT: To avoid unintentionally locking the dispenser or changing other settings, be sure to press both buttons at exactly the same time.

- Press and hold the TEMP and FAST ICE buttons at the same time again to unlock the dispenser.

The display screen indicates when the dispenser is locked.



Ice Maker and Storage Bin

- Allow 24 hours to produce the first batch of ice. Discard the first three batches of ice produced.
- The quality of your ice will be only as good as the quality of the water supplied to your ice maker. Avoid connecting the ice maker to a softened water supply. Water softener chemicals (such as salt) can damage parts of the ice maker and lead to poor quality ice. If a softened water supply cannot be avoided, make sure the water softener is operating properly and is well maintained.
- Do not use anything sharp to break up the ice in the storage bin. This can cause damage to the ice container and the dispenser mechanism.
- Do not store anything on top of or in the ice maker or storage bin.

Turning the Ice Maker On/Off

The On/Off switch can only be accessed when the ice storage bin has been removed. The switch is located on the freezer door, on the left side of the wall that surrounds the ice storage bin. See the following section for bin removal instructions.

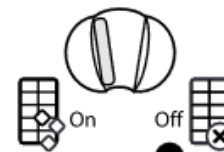

Ice Maker Control

- To turn on the ice maker, slide the control to the ON (left) position.
- To manually turn off the ice maker, slide the control to the OFF (right) position.

NOTE: The ice maker has an automatic shutoff to keep the storage bin from overflowing during normal operation. The ice maker sensors will automatically stop ice production, but the control will remain in the ON (left) position.

Dishwasher (Whirlpool WDT730PAHZ 0)

- **Operation:**

1. Load dishes into the racks, ensuring they do not obstruct the spray arms.
2. Add detergent to the dispenser and close the lid.
3. Choose your wash cycle and options.
4. Press start and close the door and a countdown will start before beginning the cycle.

OPERATING YOUR DISHWASHER

1. Prepare and load the dishwasher

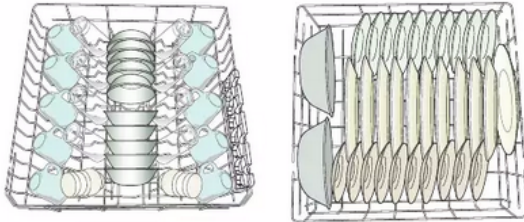

10-place load – upper rack 10-place load – lower rack

IMPORTANT: Remove leftover food, bones, toothpicks and other hard items from dishes. Remove labels from containers before washing. Make sure when dishwasher door is closed, no items are blocking detergent dispenser.

- Items should be loaded with soiled surfaces facing down and inward to the spray as shown in the graphics above. This will improve cleaning and drying results. Angle dirtiest dish surface downward, allowing space for water to flow up through rack and between dishes.
- Avoid overlapping items, like bowls or plates, that may trap food.
- Place plastics, small plates, and glasses in upper rack.
- Wash only items marked “dishwasher safe.”
- To avoid thumping/clattering noises during operation: Load dishes so they do not touch one another. Make sure lightweight load items are secured in racks.
- Additional loading patterns are available online at www.whirlpool.com.
- Use slots in the covers and suggested loading patterns to keep your silverware separated for optimum wash.

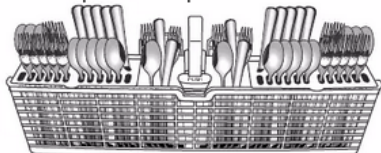

- When loading silverware, always place sharp items pointing down and avoid “nesting” as shown. If your silverware does not fit into the designated slots, flip covers up and mix silverware types to keep them separated.

NOTE: The AnyWare™ Silverware Basket can sit in the door for completely usable rack space, letting you fit more items in the rack. It can also go in your lower rack to fit your needs.

2. Check that all arms spin freely

Items in rack can block the spray arms.

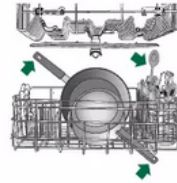

3. Add detergent

Premeasured Detergents

High quality premeasured tablets and packs are recommended for improved performance.

Quality tablets and packs have been proven better than powder, liquid, or gel detergents at reducing filming on dishes. Using tablets and packs over time will start to reduce or eliminate white film. They are suitable for all water hardness and soil levels. Also, by using a rinse aid, you can minimize repeat buildup of white film (not all packs and tablets contain rinse aid). Always place premeasured detergents in main compartment and close lid.

NOTE: Follow instructions on the package when using other dishwasher detergent types. See the complete owners manual for more details about powders, liquids, and gels.

- Use automatic dishwasher detergent only. Add detergent just before starting a cycle.
- Fresh automatic dishwasher detergent results in better cleaning. Store tightly closed detergent container in a cool, dry place.

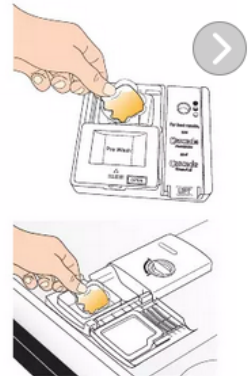

4. Add rinse aid

- Your dishwasher is designed to use rinse aid for good drying performance. Without rinse aid, your dishes and dishwasher interior will have excessive moisture. The heat dry option will not perform as well without rinse aid.

- Rinse aid keeps water from forming droplets that can dry as spots or streaks. It also improves drying by allowing water to drain off of dishes after final rinse. Rinse aid does not adhere to dishware, and when used, it is dispensed during each cycle.

- Check the rinse aid indicator with the door down (varies by model). Add rinse aid when indicator drops to "Add" level.



- Add rinse aid to hinged lid style dispenser by twisting the dispenser cap ¼ turn clockwise to open and lift off. Pour rinse aid into the opening until the indicator level is at "Full." Replace the dispenser cap and turn to "Lock." Make sure cap is fully locked.

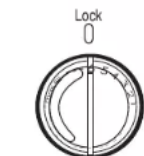

¼ turn clockwise to lock

- To add rinse aid to sliding lid style dispenser, open the rinse dispenser lid by gently pushing the center of the lid with your thumb and pulling up on the edge. Pour rinse aid into the opening until the dispenser is full. Then, close the dispenser by pushing down gently on the lid.

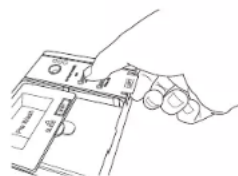

NOTE: For most water conditions, the factory setting will give good results.

If you are experiencing poor drying performance, you may want to try a higher setting. Turn the arrow adjuster to a higher number to increase the amount of rinse aid.



5. Select a cycle (varies by model)

Efficient dishwashers run longer to save water and energy, just as driving a car slower saves on gas. Typical cycle time is approximately 2½ hours, but can take less or more time to complete, depending on selections.

6. Select options (varies by model)

You can customize your cycles by pressing the options desired. If you change your mind, press the option again to turn off the option. Not all options are available for every cycle. If an invalid option is selected for a given cycle, the lights will flash. Adding options may increase the cycle time displayed.

7. Follow the progress of your dishwasher

The fully lit display will glow for wash, drain, drying, sanitized, and clean. It will also display the remaining time for the cycle in hours and minutes.



Select the desired cycle by pressing the Cycles button. Each time the Cycles button is pressed, the next available cycle will be displayed.

8. Start or resume a cycle

NOTE: Run hot water at the sink nearest your dishwasher until the water is hot. Turn off water.

- If the Start/Resume button is located on top of door; push door firmly closed within 3 seconds of pressing Start/Resume. If door is not closed within 3 seconds, the Start button LED will flash, an audible tone will be heard, and cycle will not start.









IMPORTANT: If anyone opens the door (such as, for adding a dish, even during the Delay Hours option), the Start/resume button must be pressed each time.

- If your Start/Resume button is located on front of door: push door firmly closed. The door latches automatically. Select a wash cycle, options, and press START/RESUME or press START/RESUME to repeat the same cycle and options as in previous wash cycle.

CYCLE GUIDE

This information covers several different models. Your dishwasher may not have all of the cycles and options described. Estimated cycle times may increase or decrease depending on water temperature, soil conditions, dish load size, and options selected.

CYCLES		ESTIMATED WASH TIME DISPLAYED H:MM W/O OPTIONS	WATER USAGE GALLONS (LITERS)
Sensor	The most advanced and versatile cycle. This cycle senses load size, soil amount, and toughness of soil to adjust the cycle for ideal cleaning, using only the amount of water and energy needed. Use for all soil levels.	2:30	3.38 to 7.4 (12.8 to 28.0)
Heavy	Use for hard-to-clean, heavily soiled pots, pans, casseroles, and tableware.	3:28	7.4 (28.1)
Normal	This cycle with only the Heated Dry option selected, and without other options selected, is recommended to completely wash and dry a full load of normally soiled dishes. The energy usage label is based on this cycle and option combination.	2:32	2.4 to 7.4 (9.09 to 28)
1-Hour Wash	For fast results, 1-Hour Wash will clean dishes using more water and energy. Select the Heat Dry option to provide best dry performance. May be used for all soil levels.	1:00	7.87 (29.8)
Soak & Clean	This cycle quietly soaks dishes with an extended prewash which eliminates the need to presoak dishes, saving personal time and effort. For optimal cleaning results during the Soak & Clean cycle add prewash detergent. Use this cycle for loads with heavy amounts of dried on or hard to clean baked-on food.	7:31	7.4 (28.0)

	OPTIONS	CAN BE SELECTED WITH	WHAT IT DOES	ADDED TIME TO CYCLE	ADDED WATER GALLONS (LITERS)
	<p>Activates the TargetClean™ spray jets and provides intensified water spray to back of lower level rack.</p> <p>May add heat and time to cycle.</p>	Sensor Heavy Normal Soak & Clean	Raises main wash temperature from 105°F (41°C) to 120°F (49°C).	0:12 to 0:57	0 to 4.8 (0 to 18.2)
	<p>Raises main wash temperature to improve cleaning for loads containing tough, baked-on food.</p>	Sensor Heavy Normal Soak & Clean	Raises the main wash temperature to 135°F (57°C).	0:05 to 0:13	0 to 3.86 (0 to 14.6)
	<p>Sanitizes dishes and glassware in accordance with NSF International NSF/ANSI Standard 184 for Residential Dishwashers. Certified residential dishwashers are not intended for licensed food establishments. Only sanitizing cycles have been designed to meet the requirements of the NSF/ANSI 184 performance standard for soil removal and sanitization efficacy. There is no intention, either directly or indirectly, that all cycles on a NSF/ANSI 184 certified dishwasher meet the NSF/ANSI 184 performance standard for soil removal and sanitization efficacy.</p> <p>Sani Rinse indicator is lit at the end of the cycle if the Sani Rinse option was successfully completed. If indicator does not light, it is probably due to the cycle being interrupted.</p>	Sensor Heavy Normal	Raises the main wash temperature to 135°F (57°C) and the final rinse temperature to 156°F (69°C).	0:05 to 1:06	0 to 3.86 (0 to 14.6)
	<p>Dries dishes with heat. This option, with the use of rinse aid, will provide the best drying performance. Plastic items are less likely to deform when loaded in the top rack. Use Heat Dry for optimum dry performance. Turn the Heat Dry option off for air dry.</p>	Sensor Heavy Normal Soak & Clean	Uses heating element to speed drying times. Heat Dry option defaults to On when any cycle is selected, except for 1- Hour Wash.	0:08 to 0:46	0
	<p>Runs dishwasher at a later time. Select a wash cycle and options. Each time you press the delay button it will display the next available delay time. Press DELAY. Press START/RESUME. Close door firmly.</p> <p>NOTE: The dishwasher remembers the last Delay you selected. To reset the delay time to something other than what is displayed, continue to press the Delay button until the desired delay time is reached.</p> <p>NOTE: Anytime the door is opened (such as, to add a dish); Start/Resume must be pressed again to resume delay countdown.</p>	Available with any cycle	Delays start of a cycle up to 24 hours.	0:00	0
	<p>Avoids unintended use of dishwasher between cycles or cycle and option changes during a cycle.</p> <p>To turn on Lock, press and hold SANI RINSE/CONTROL LOCK or DELAY (depending on model) for 3 seconds. Control Lock light will stay on for a short time, indicating that it is activated and all buttons are disabled. If you press any button while your dishwasher is locked, light flashes 3 times. Dishwasher door can still be opened/closed while the controls are locked.</p> <p>To turn off Lock, press and hold SANI RINSE/CONTROL LOCK or DELAY (depending on model) for 3 seconds. Light turns off.</p> <p>NOTE: If your model requires you to press and hold DELAY to lock controls, Control Locked LED will be on or off to indicate whether Control Lock is active or not.</p>				
Control	Purpose	Comments			
	Press to start or resume a wash cycle.	If the door is opened during a cycle or the power is interrupted, the Start/Resume button LED flashes. Cycle will not resume until door is closed and Start/Resume is pressed. NOTE: If Start/Resume button is located on top of door, push door firmly closed within 3 seconds of pressing Start/Resume. If door is not closed within 3 seconds, Start/Resume button LED will flash, an audible tone will be heard (on some top control models), and cycle will not start.			
	Press to cancel wash cycle.	If Start/Resume button is located on top of door, press and hold START/RESUME for 3 seconds. Close the door firmly. The dishwasher starts a 2-minute drain (if needed). Let dishwasher drain completely.			
	To follow progress of your dishwasher cycle.	The Clean indicator glows when a cycle is finished. If you select Sani Rinse option, when cycle is finished, the "Sanitized" indicator glows. If your dishwasher did not properly sanitize your dishes, the light flashes at the end of the cycle. This can happen if the cycle is interrupted, or water could not be heated to required temperature. The light goes off when you open and close door or press CANCEL.			
	NOTE: Indicators shown are not available on all models.				

DISHWASHER CARE

Cleaning the Dishwasher

Clean the exterior of dishwasher with a soft, damp cloth and mild detergent. If your dishwasher has a stainless steel exterior, a stainless steel cleaner is recommended - Stainless Steel Cleaner and Polish Part Number 31462A.

Removal of Hard Water/Filming: Recommended use of a monthly maintenance product such as affresh® Dishwasher Cleaner Part Number W10282479.

- Load your dishwasher (preferably with dishes affected by filming / hard water).
- Place tablet in main wash compartment of detergent dispenser.
- Select cycle/option best for heavily soiled dishes and start dishwasher.

NOTE: Recommended to use a premeasured detergent tablet or pack for regular daily use.

If you have a drain air gap, check and clean it if the dishwasher isn't draining well.

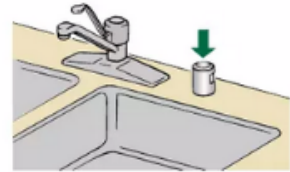

To Reduce Risk of Property Damage During Vacation or Extended Time Without Use

- When you will not be using the dishwasher during the summer months, turn off the water and power supply to the dishwasher.
- Make sure the water supply lines are protected against freezing conditions. Ice formations in the supply lines can increase water pressure and cause damage to your dishwasher or home. Damage from freezing is not covered by the warranty.
- When storing your dishwasher in the winter, avoid water damage by having your dishwasher winterized by authorized service personnel.

TROUBLESHOOTING

First try the solutions suggested here. If you need further assistance or more recommendations that may help you avoid a service call, refer to the Troubleshooting page in this manual and scan the code there with your mobile device, or visit www.whirlpool.com/product_help for recommendations that may help you avoid a service call. In Canada, visit <http://www.whirlpool.ca>.

Contact us by mail with any questions or concerns at the address below:

In the U.S.A.:

Whirlpool Brand Home Appliances
Customer eXperience Center
553 Benson Road
Benton Harbor, MI 49022-2692

In Canada:

Whirlpool Brand Home Appliances
Whirlpool Canada LP
200 – 6750 Century Ave.
Mississauga ON L5N 0B7

Please include a daytime phone number in your correspondence.

If you experience	Recommended Solutions
Dishwasher does not run or stops during a cycle	<p>It is normal for certain cycles to repeatedly pause for several seconds during the main wash. Is the door closed tightly and latched?</p> <p>Is the right cycle selected?</p> <p>Is there power to the dishwasher? Has a household fuse blown, or has a circuit breaker tripped? Replace the fuse or reset the circuit breaker. If the problem continues, call an electrician.</p> <p>Has the motor stopped due to an overload? The motor automatically resets itself within a few minutes. If it does not restart, call for service.</p> <p>Is the water shutoff valve (if installed) turned on?</p>
The Clean Indicator is flashing	<p>Check the following:</p> <ul style="list-style-type: none"> ■ Is the overflow protection float able to move up and down freely? Press down to release. ■ Be sure the water supply is turned on to the dishwasher. (This is very important following the new installation of your dishwasher.) ■ Check for suds in the dishwasher. If foam or suds are detected by the dishwasher sensing system, the dishwasher may not operate properly or may not fill with water. Suds can come from: <ul style="list-style-type: none"> ■ Using the incorrect type of detergent, such as laundry detergent, hand soap, or dish detergent for hand washing dishes. ■ Forgetting to replace the rinse aid dispenser cap after filling (or refilling) the rinse aid. ■ Using an excessive amount of dishwasher detergent.

If you experience	Recommended Solutions
Dishes do not dry completely	<p>NOTE: Plastic and items with nonstick surfaces are difficult to dry because they have a porous surface which tends to collect water droplets. Towel drying may be necessary.</p> <p>Use of rinse aid along with Heat Dry option is needed for proper drying.</p> <p>Proper loading of items can affect drying.</p> <p>Glasses and cups with concave bottoms hold water. This water may spill onto other items when unloading.</p> <ul style="list-style-type: none"> ■ Unload the bottom rack first. ■ For improved results, place these items on the more slanted side of the rack.
Noise	<p>NOTE: Common noises:</p> <ul style="list-style-type: none"> ■ Surging sounds can occur periodically throughout the cycle while the dishwasher is draining. ■ Normal water valve hissing may be heard periodically. ■ A normal snap sound may be heard when the detergent dispenser opens during the cycle or when the door is opened at the end of the cycle. ■ Improper installation will affect noise levels. <p>Be sure the filters are properly installed.</p> <p>A thumping sound may be heard if items extend beyond the racks and interfere with the wash arms. Readjust the dishware and resume the cycle.</p>
Spotting/Filming	<p>Liquid rinse aid is necessary for drying and to reduce spotting.</p> <p>Use the correct amount of detergent.</p> <p>Confirm that the cloudiness is removable by soaking the item in white vinegar for 5 minutes. If the cloudiness disappears, it is due to hard water. Adjust the amount of detergent and rinse aid (see "Dishwasher Care" section in full Use and Care Guide). If it does not come clear, it is due to etching.</p> <p>Be sure the incoming water temperature is set at 120°F (49°C).</p> <p>Try using the High Temp and Sani Rinse options.</p> <p>To remove spotting, run a vinegar rinse through the dishwasher.</p> <ul style="list-style-type: none"> ■ Wash and rinse the affected dishware and load into dishwasher. Remove all silverware and metal items. Put 2 cups (500 mL) of white vinegar in a glass measuring cup in the lower rack. Run a normal cycle with the Heat Dry option turned off. No detergent is needed (see "Dishwasher Care" section in full Use and Care Guide).
Dishwasher does not clean completely	<p>Be sure the dishwasher is loaded correctly. Improper loading can greatly decrease the washing performance (see Operating Your Dishwasher" section).</p> <p>Check filter to ensure it is properly installed. Clean it if needed. (See "Filtration System" in full User Guide for details.)</p> <p>Select the proper cycle for the type of soils. The Sensor Wash or the Heavy Wash cycles can be used for tougher loads.</p> <p>Be sure the incoming water temperature is at least 120°F (49°C).</p> <p>Use the proper amount of fresh detergent. More detergent is needed for heavier-soiled loads and hard water conditions.</p> <p>Scrape food from dishes prior to loading (do not prerinse).</p> <p>If foam or suds are detected by the dishwasher sensing system, the dishwasher may not operate properly or may not fill with water.</p> <p>Suds can come from:</p> <ul style="list-style-type: none"> ■ Using the incorrect type of detergent, such laundry detergent, hand soap, or dish detergent for hand washing dishes. ■ Not replacing the rinse aid dispenser cap after filling (or refilling) the rinse aid. ■ Using an excessive amount of dishwasher detergent.
Dishwasher does not drain	<p>Be sure the cycle has been completed (the Clean light is on). If it has not, you will need to resume the cycle by closing the door and pressing START/RESUME.</p> <p>If dishwasher is connected to a food waste disposer, be sure the knockout plug has been removed from the disposer inlet.</p> <p>Check for kinks in the drain hose.</p> <p>Check for food obstructions in the drain or disposer.</p> <p>Check your house fuse or circuit breaker.</p>

Fire Pit

Please put cooled ash in the container provided using the included scooper tool. There is also a hook on the deck to put the lid when the pit is in use.



Safety and Usage

1. **Supervision Required:** Always supervise the fire pit when in use. Never leave the fire unattended.
2. **Age Restriction:** Only adults 18 years and older may operate the fire pit.
3. **Starting the Fire:** Use only recommended fire starters (like kindling or commercial fire starters). Never use gasoline, kerosene, or other flammable liquids to start or reignite the fire.
4. **Fire Pit Cover Usage:** Always use the fire pit cover when the pit is not in use to prevent embers from escaping. Remove the cover only when ready to start a fire and replace it after the fire has been completely extinguished.
5. **Keep a Safe Distance:** Maintain a safe distance from the fire pit. Keep all furniture, decorations, and flammable materials at least 3 feet away from the fire.
6. **Waste Disposal:** Do not burn trash, plastics, or any materials besides firewood. Use only seasoned wood to minimize smoke and sparks.
7. **Weather Considerations:** Do not use the fire pit in windy conditions as this can spread sparks and embers to nearby combustibles.
8. **Safety Equipment:** A garden hose, or water bucket nearby for emergency use.
9. **Local Laws and Regulations:** Adhere to all local fire regulations and burn bans. Check local fire safety rules to ensure compliance.
10. **Guest Capacity:** Limit the number of people around the fire pit to ensure safety and control.
11. **Reporting Issues:** Immediately report any damage to the fire pit or safety equipment to the host.

Outside Patio Furniture

Please ensure the umbrella is closed and secured with the Velcro tab that's provided when not in use.

Garbage Information

Garbage pickup is on Friday mornings. Please ensure all garbage is placed in the Michiana garbage bins and rolled out to the end of the driveway Thursday Night. After pickup, please return the cans to the side of the garage

Guest Wi-Fi and Technology Use

Please refrain from making any changes to this setup

- **Wi-Fi Network:** Farmhouse2118
- **Password:** OldMacDonaldFarm1998
- **Router Restart Instructions:** Please reach out via AirBnb chat to ask for this to be done.



Property Layout and Access

- **Games, Towels, and Essentials:**
 - Games (upstairs closet by bathroom).
 - Extra towels (upstairs closet by bathroom).
 - Toilet paper (main entryway bathroom closet).
- **Dish Soap and Cleaning Supplies:** Found under the kitchen sink.

Emergency Contacts and Safety Information

- **Police: Emergency 911 Non-Emergency (269)-695-5120**
- **Fire: Emergency 911 Non-Emergency (269)-695-5592 Extinguisher:** Below the Kitchen Sink
- **Hospital:** Lakeland Hospital, Niles, MI (269) 683-5510
- **In Case of Power Outage:** The code to access downstairs is 911911 (door located in the kitchen and positioned closest to the coffee bar).
- **First Aid Kit:** Under the kitchen sink next to the fire extinguisher.



Security Measures

For the safety of our guests and the protection of our property, we have installed security cameras in the external areas of our home. These cameras are located at the front door, garage, patio, and back porch. Please note that these cameras are only active in outdoor areas and do not infringe upon private spaces to ensure your privacy. The cameras are strictly for security purposes and to ensure the property remains safe and secure for all our guests. We appreciate your understanding and cooperation.

Social Media Participation

We love seeing your memories! Share your moments with us on social media TBD.

Final Note

An online copy of this guide is sent ahead of time, and a hard copy is available in the house for your convenience. We hope this guide helps make your stay enjoyable and comfortable. Should you have any questions or need assistance, do not hesitate to contact us.